

Assembly bends, shrinkable, L=1000mm

Belmaflex assembly bends, shrinkable are made of PE 100 and find their application on the existing pipe lines. On customer request, products may be supplied with loose mastic bands and shrinkable collars. Assembly bends can be supplied in two wall thickness versions; standard or extra thickness which is an advantage in case of welding.

Assembly Bends 45°, product drawing

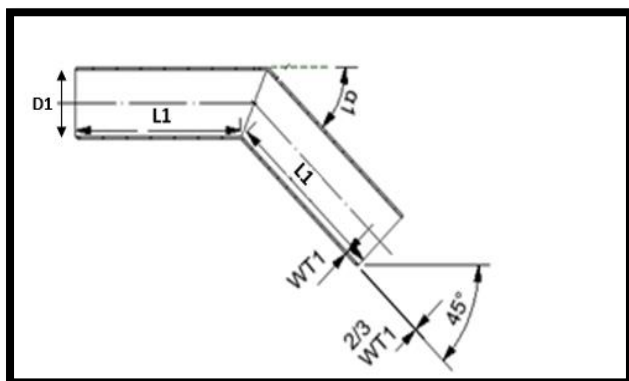

Assembly Bends 45°, L1 = 1000 mm, measurement parameters

Item no - standard wall thickness	Item no - extra wall thickness	D1*	Standard version	Extra wall thickness version	No of segments	L1
			wall thckn. mm	wall thckn. mm		mm
7707510004512		75	3		0	1000
7709010004512	7709010004515	90	3	4	0	1000
7711010004512	7711010004515	110	3	4	0	1000
7712510004512	7712510004515	125	3	4,1	0	1000
7714010004512	7714010004515	140	3	4,5	0	1000
7716010004512	7716010004515	160	3	5	0	1000
7718010004512	7718010004515	180	3	5	0	1000
7720010004512	7720010004515	200	3,2	5	0	1000
7722510004512	7722510004515	225	3,5	5,5	0	1000
7725010004512	7725010004515	250	3,9	6,1	0	1000
7728010004512	7728010004515	280	4,4	6,9	0	1000
7731510004512	7731510004515	315	4,9	7,7	0	1000

*D1 - outer PE casing diameter on which assembly bend will be shrinked

Assembly bends in different diameters, with different angles, lengths and number of segments can be supplied on special request of the customer

In case of a special request for a not standard assembly bends in angles $\leq 45^\circ$ please send us the product drawing or fill up the information in the table in the CUSTOMER NOT STANDARD PRODUCT REQUEST FORM on page no 3

Assembly bends, shrinkable, L=1000mm

Assembly Bends 90°, product drawing

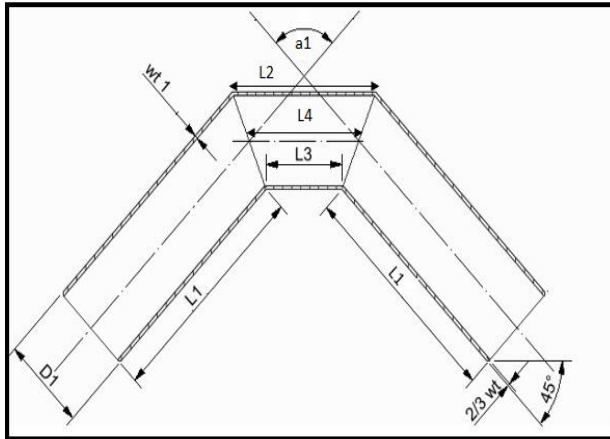

Assembly Bends 90°, L1 = 1000 mm, measurement parameters

Item no - standard wall thickness	Item no - extra wall thickness	D1*	Standard version	extra wall thickness version	No of segm.	L1	L2	L3
			wall thckn. mm	wall thckn. mm		mm	mm	mm
7707510009012		75	3		0	1000	152	90
7709010009012	7709010009015	90	3	4	1	1000	164	90
7711010009012	7711010009015	110	3	4	1	1000	180	90
7712510009012	7712510009015	125	3	4,1	1	1000	192	90
7714010009012	7714010009015	140	3	4,5	1	1000	206	90
7716010009012	7716010009015	160	3	5	1	1000	222	90
7718010009012	7718010009015	180	3	5	1	1000	240	90
7720010009012	7720010009015	200	3,2	5	1	1000	255	90
7722510009012	7722510009015	225	3,5	5,5	1	1000	276	90
7725010009012	7725010009015	250	3,9	6,1	1	1000	297	90
7728010009012	7728010009015	280	4,4	6,9	1	1000	332	100
7731510009012	7731510009015	315	4,9	7,7	1	1000	370	110

*D1 - outer PE casing diameter on which assembly bend will be shrinked

Assembly bends in different diameters, with different angles, lengths and number of segments can be supplied on special request of the customer

In case of a special request for a not standard assembly bends in angles >45° please send us the product drawing or fill up the information in the table in the CUSTOMER NOT STANDARD PRODUCT REQUEST FORM on page no 4